

Practical TED's use in strain gage applications

Chris Gibson
VTI Instruments

TEDs an IEEE Standard

- Defined IEEE standard (IEEE 1451)
- Frequently used in other non-expendable transducers
 - Accelerometers
 - Load Cells
- Not commonly used for strain gauges
- Used for transducer Identification
- Can also contain sensitivity or measurement parameters

TED's Technology



- Primary TED's ID chips manufactured by Dallas Semiconductor
- ID Chips available in a number of form factors
 - TO-92
 - iButton
- Each TED's ID chip has an individual laser etched serial number
- DS2431 (standard) also has 256 bits of flash memory
- 1 wire communication bus
- Ideally the ID chip would be co-located with the transducer

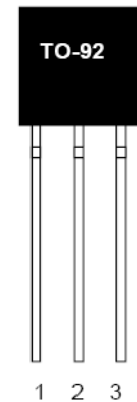

TEDs in Practice

- Transducer performance Critical
 - Introduction of TED's ID chip should not alter transducer performance in anyway
 - Users not comfortable with TED's in primary measurement path
- Design needs to be flexible
 - Different users will need to implement in a manner that suits their needs
- Needs to be low cost

TEDs and the RJ-45

- Boeing worked with VTI to create a standard that would allow TEDS to be used with the RJ-45 connector
 - Wanted to take advantage of TEDs
 - Had already standardized on the RJ-45 because of low cost and ease of use
 - Had a need to use for the upcoming 787 9000 channel structural test

RJ-45 1/4 Bridge Signal paths

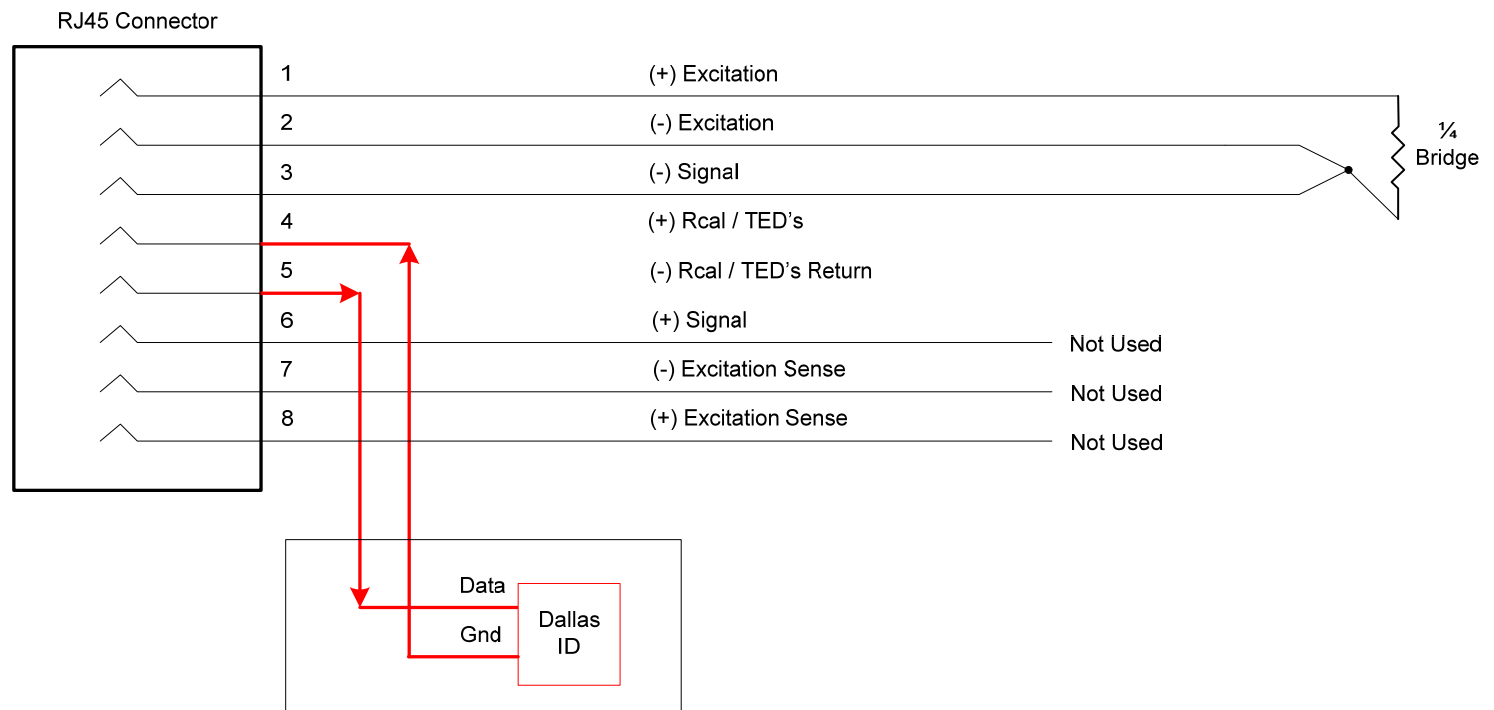

RJ-45 1/2 Bridge Signal paths

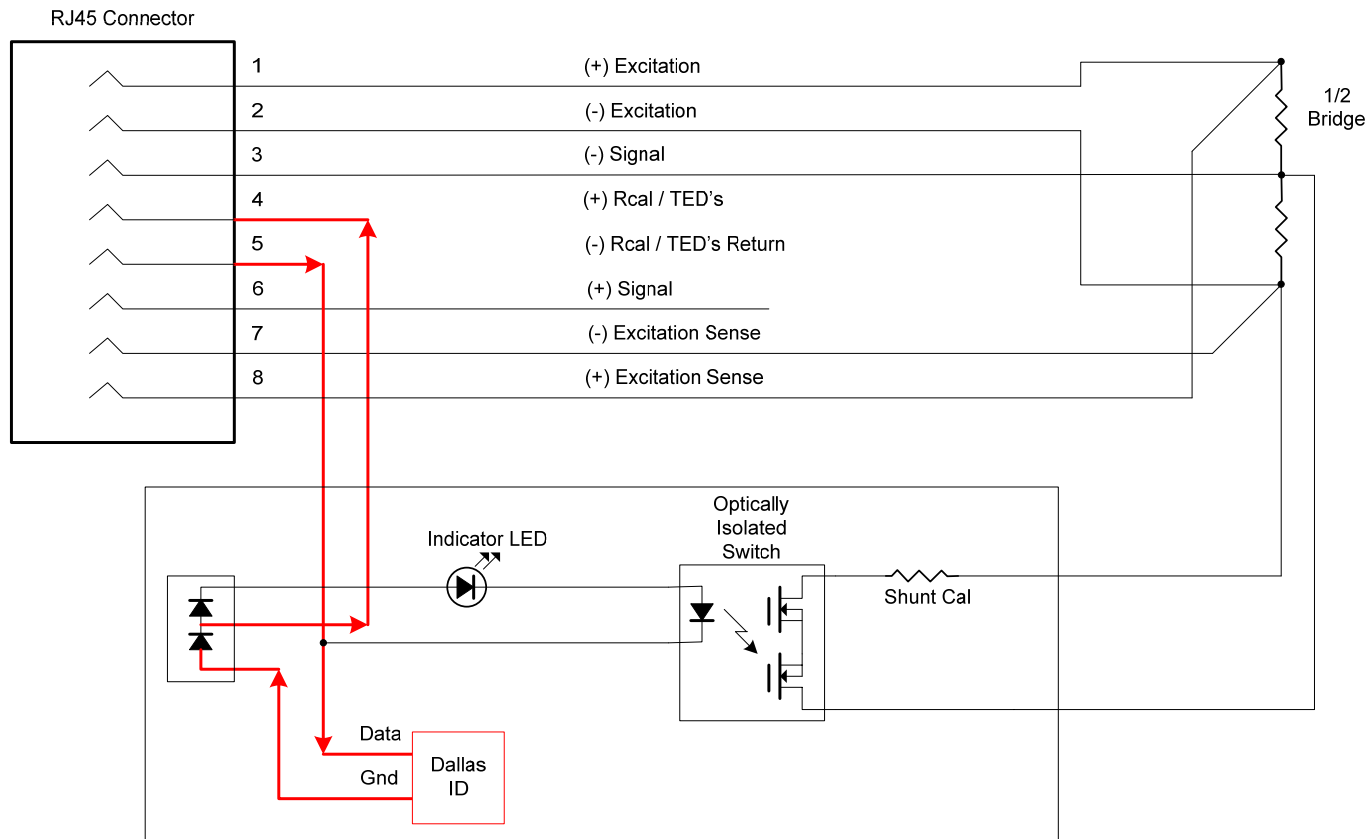

RJ-45 Full Bridge Signal paths with current on pins 4 and 5 Biased to read TED's information

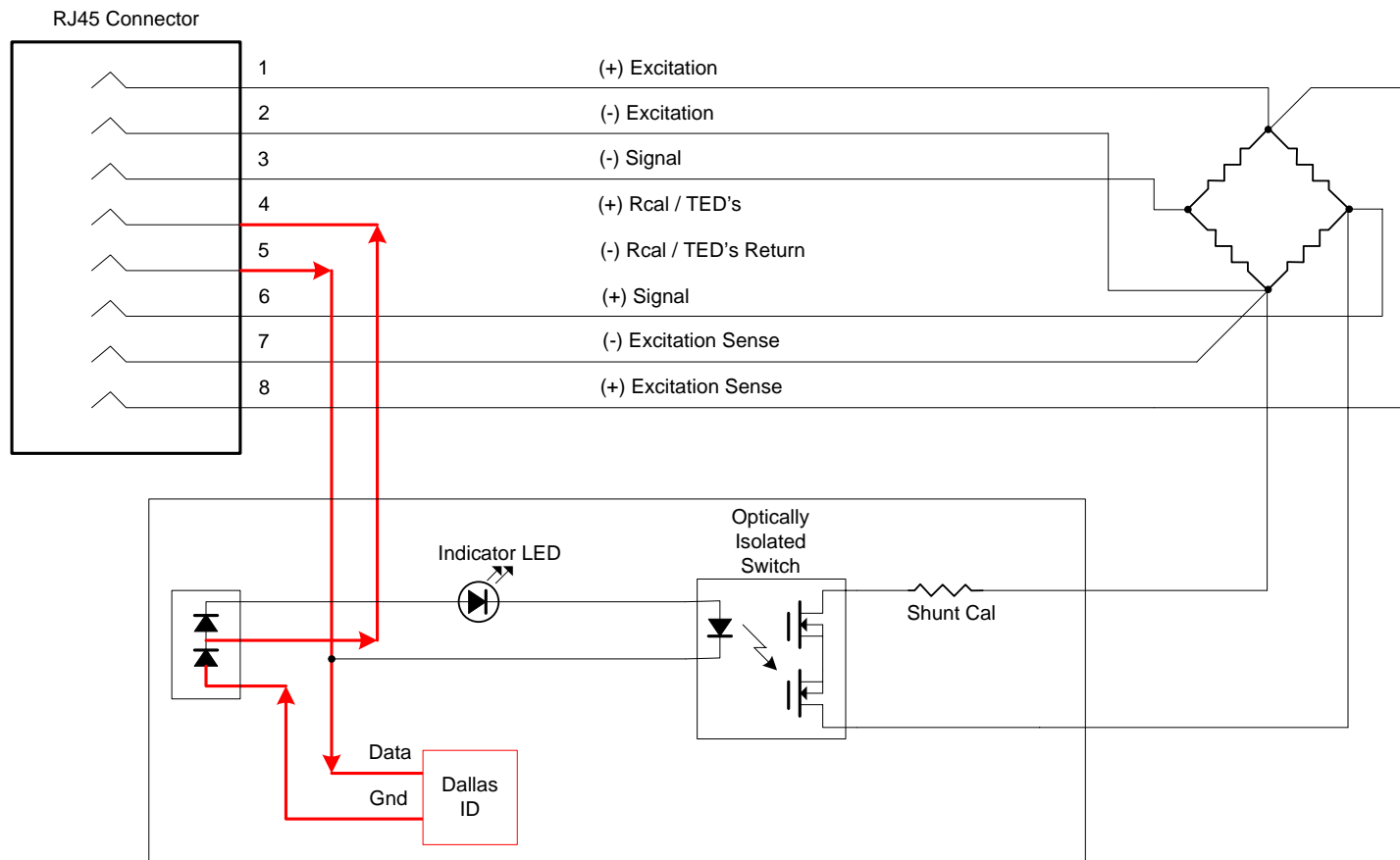

RJ-45 Signal paths with current on pins 4 and 5 Biased to do remote shunt calibration

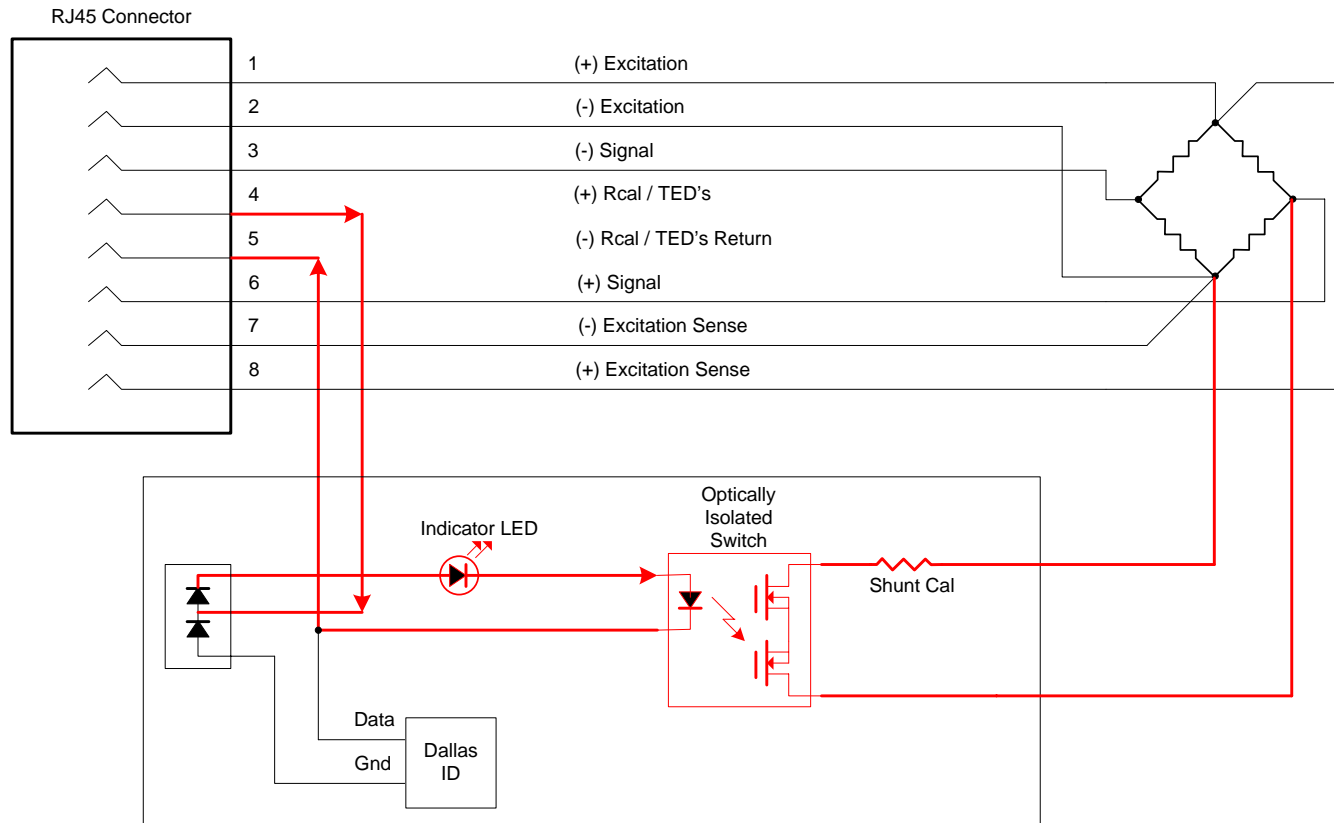

Case Study- Corporation

- 787 Aircraft Measurement Challenges
- New airplane utilizes new materials
 - Composites required high channel counts
 - Low excitation levels needed to reduce gauge heating
- Schedule pressure
 - Gauge installation and identification
 - Improved cable management
- The Global manufacturing challenge?

Boeing 787 Structural Suppliers

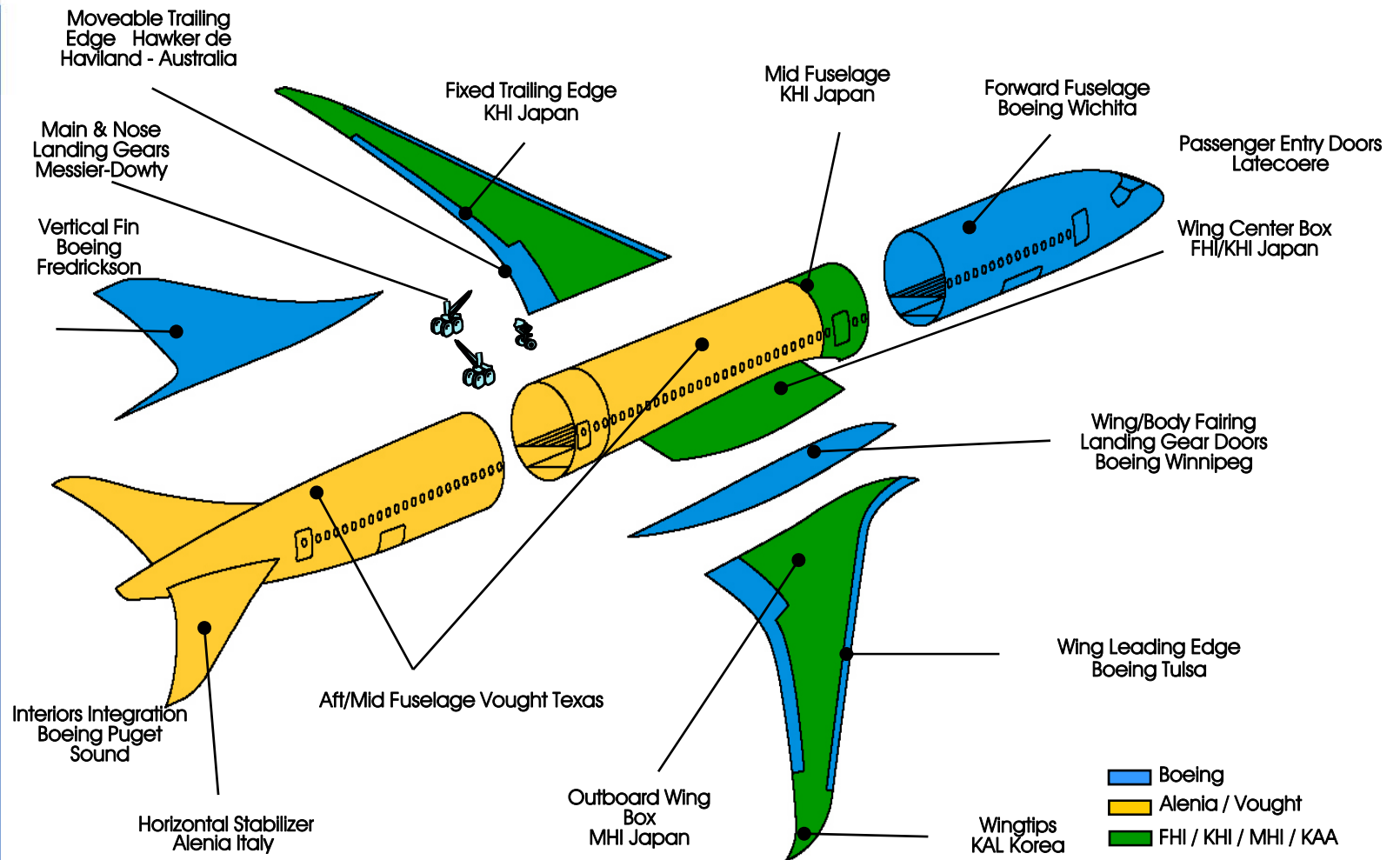

TED's Implementation



- Gauges installed at place of manufacture
 - Some gauges installed into “blind” or inaccessible locations
- TED's ID chip installed into the RJ-45 connector
 - Majority of measurements are $\frac{1}{4}$ bridge
- USB Reader used to read ID information after installation
- Installation information along with location and ID recorded into master instrumentation data spreadsheet
- VTI Instruments EX1629 used to read transducer ID when connected at final test location

Wiring Diagram of Typical Axial Strain Gauge Installation

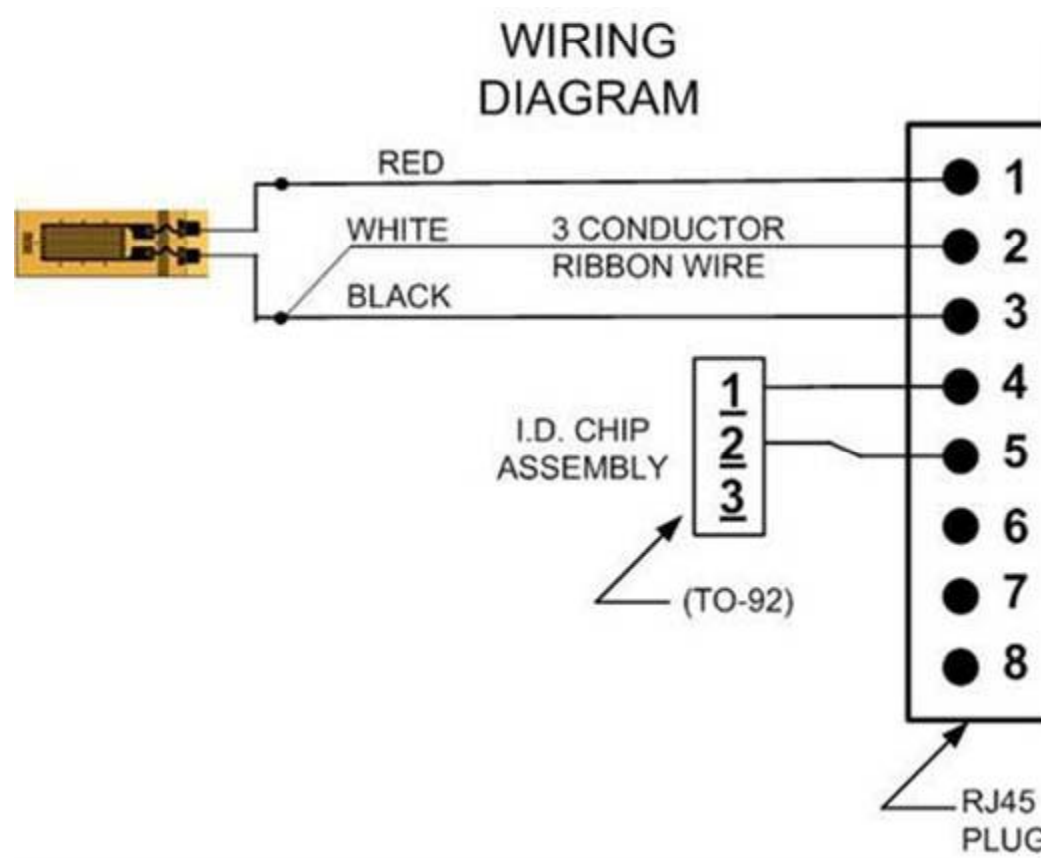

Dallas TED's chip is installed in the RJ-45 plug providing unique serial number for each transducer

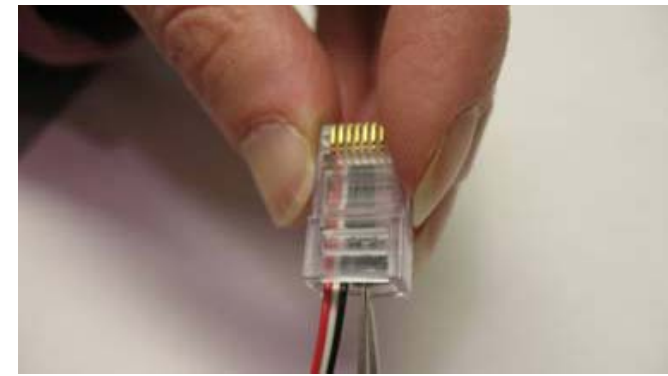
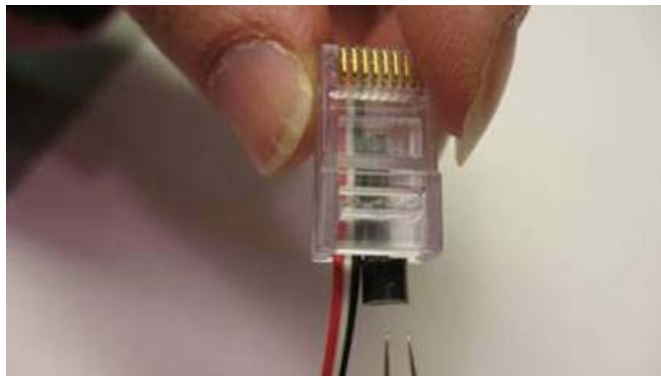
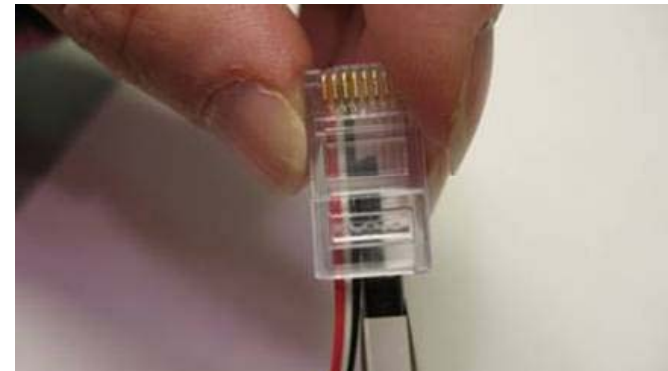
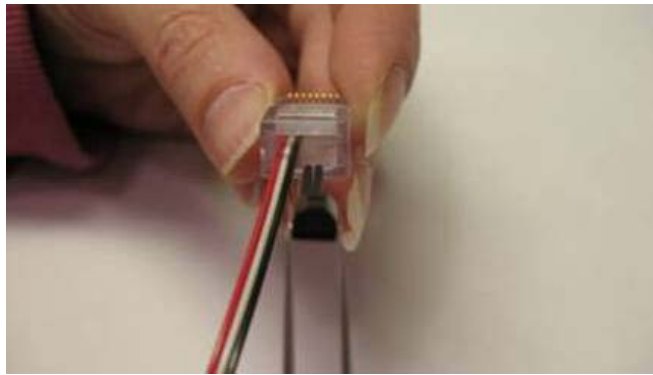

RJ45 to RJ11 Adapter Cable Wiring used to read directly read installed gauges

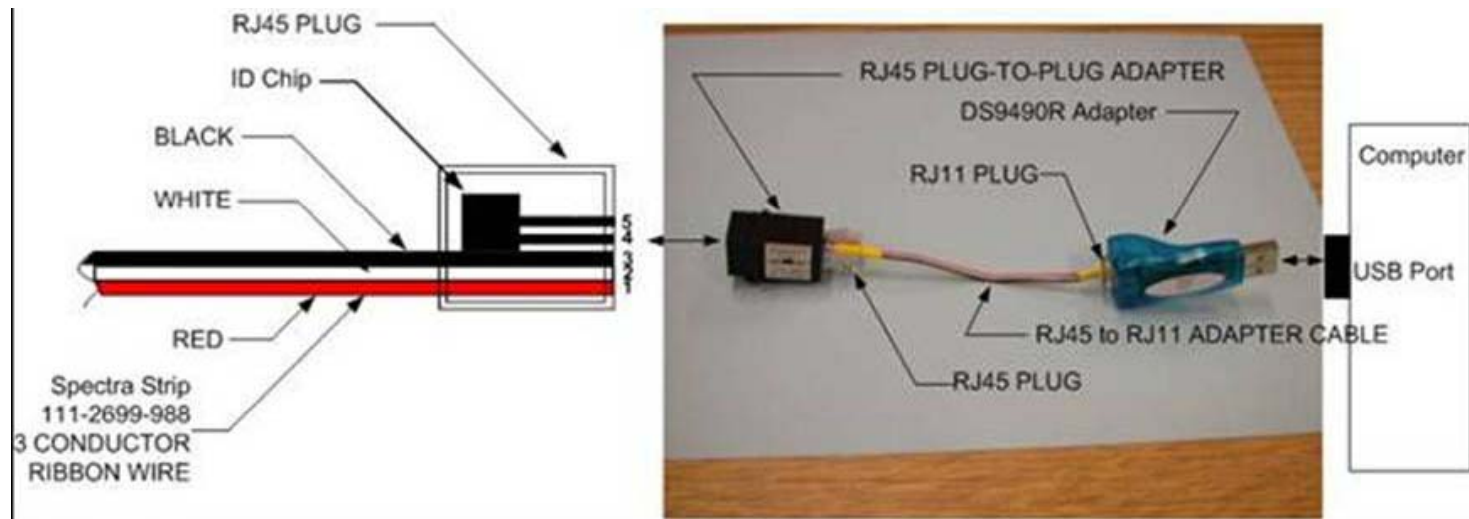

Conclusions

- User able to improve setup and wiring accuracy through the use of an Open TED's implementation
- Improvement of test schedule by months not weeks through the use of TED's
- Cost of implementation is around \$1 per channel in cost, bringing the cost of utilizing TED's for a large scale 10,000 test to affordable levels
- Open implementation of TED's allows User to use any manufacturers transducers including existing load cells and displacement transducers
- TED's becomes an essential tool to control cost and schedule in competitive testing requirements

